

Rohde & Schwarz / Bharat 6G

5G-ADVANCED TRAILBLAZING THE EVOLUTION TOWARDS 6G



Mahesh Basavaraju

Global Market Segment Manager
Wireless Communication



3GPP STANDARDIZATION AND REGULATION ON THE WAY TOWARDS PLANNED 6G LAUNCH IN 2030

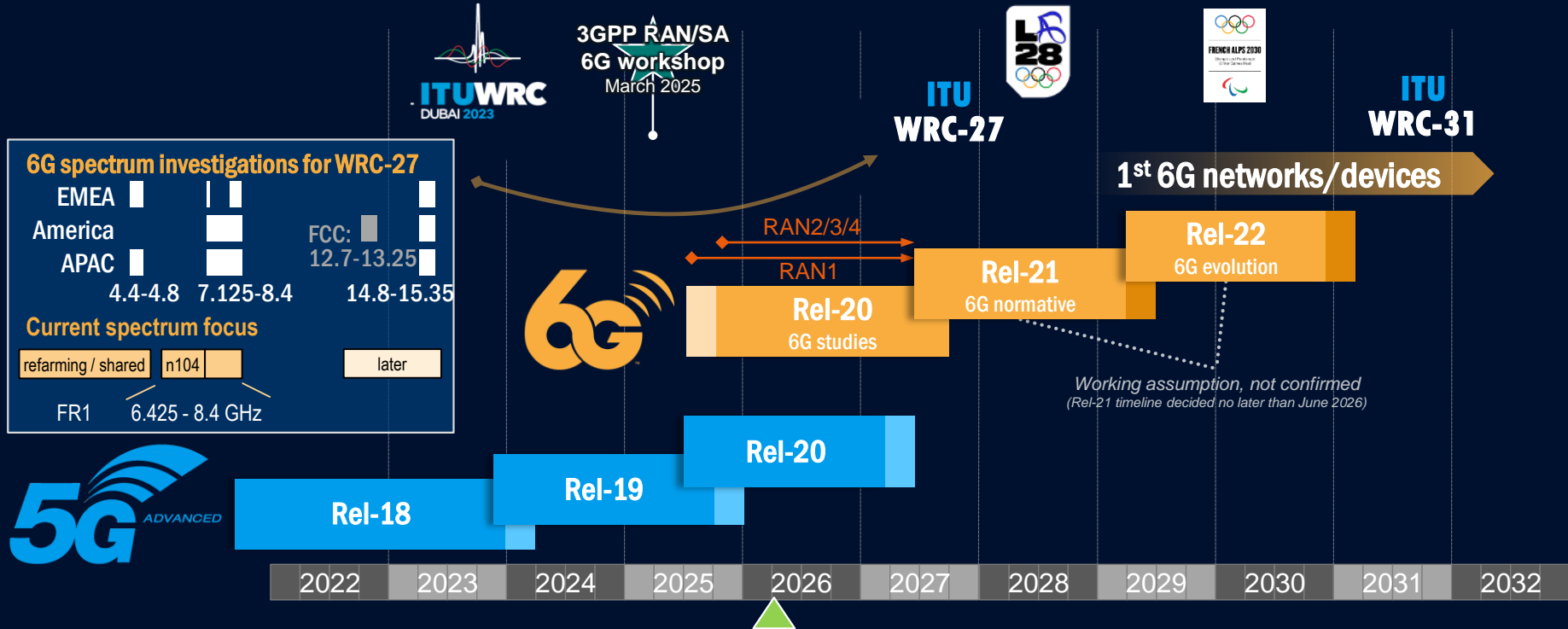



MAIN TECHNOLOGY PILLARS

NTN

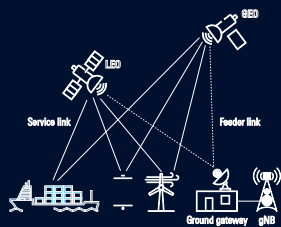

The Metaverse and eXtended Reality (XR)

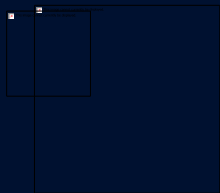

AI -RAN



FR3 / Giga-MIMO



Integrated sensing and communication



Enhanced Duplex



Open networks and distributed computing



Photonics



Security & Trustworthiness



MAIN TECHNOLOGY PILLARS



NTN

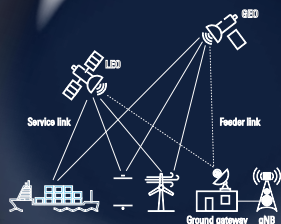

The Metaverse and Extended Reality (XR)



AI -RAN



FR3 / Giga-MIMO



Integrated sensing and communication



Enhanced Duplex



Open networks and distributed computing



Photonics



Security & Trustworthiness

NTN IN 3GPP STANDARDIZATION - EVOLUTION



Rel. 21 6G unified 3D network

Rel. 15 Study item to support NTN

- TR 38.811:
- Channel models
 - Frequency aspects
 - Device types
 - Antenna models
 - Satellite constellations
 - Deployment scenarios

Rel. 16 Study item for NTN solutions.

- TR 38.821:
- Architecture models
 - PHY aspects
 - Protocol aspects
 - NG-RAN interfaces
 - Recommendations to enable NTN

NTN Rel. 17

- 5G enabling NTN
- Transparent payload
- Protocol stack enhancement
- Timer + Doppler shift compensation + GNSS support
- HARQ update, Cond. Handover, Switchover
- SIB19 + RRC update
- Frequency < 6GHz

NTN Rel. 18

- Frequency > 10GHz
- VSAT category UE
- Coverage enhancements
- Mobility enhancements
- NW verified UE location

NTN Rel. 19

- Regenerative payload
- DL coverage enhancements
- TN – NTN mobility enhancements
- SIB25 intro
- RedCap UE supporting NTN
- Throughput enhancements
- IoT-NTN store & forward

NTN Rel. 20

- GNSS free / resilient operation
- IoT-NTN voice
- EUTRA TN to NR NTN handover
- IoT-NTN power class 1



SATELLITE COMMUNICATIONS - FOUR PARADIGMS

E.g. supplementary
satellite coverage
(TN MNO shares
spectrum with Sat
MNO)

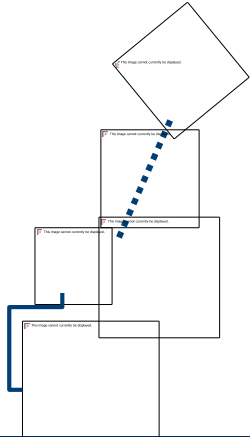

Non-3GPP sat communications

- Smartphone with additional RF frontend & modem
- Dedicated spectrum
- Sat constellation available
- Dedicated use cases: e.g. messaging
- Dedicated ecosystem

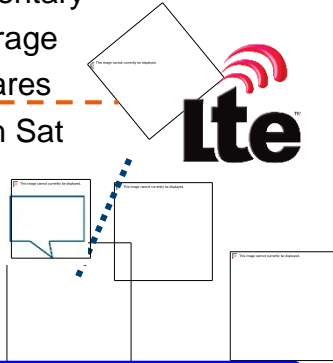

Spectrum sharing / MSS

Direct to cell (DTC) communications

- Legacy smartphone
- Spectrum sharing or MSS spectrum
- Doppler compensation at satellite => efficiency!
- Early service-offering (time to market)
- Limited efficiency & capacity

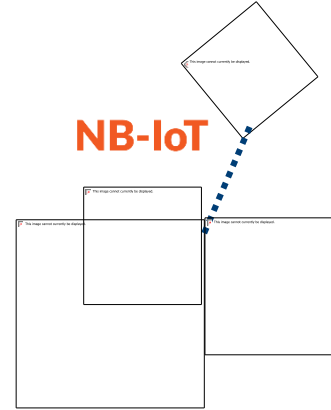

4G/5G IoT-NTN (satellite NB-IoT)

- Rel. 17+ IoT devices
- Dedicated sat spectrum (S and L-band). < 6GHz
- Limited capacity, low datarate
- Best effort QoS, delay tolerant
- 4G NB-IoT based, future 5G (e)RedCap

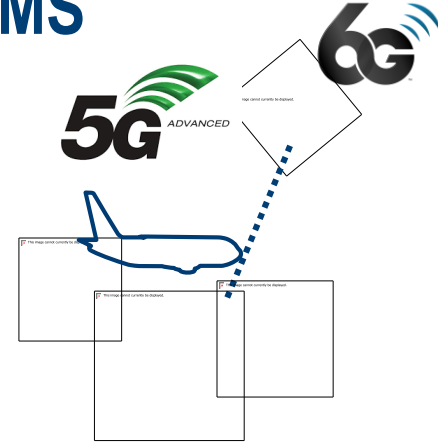

NR-NTN (satellite to everything)

- New silicon UE with Rel. 17+ capabilities, various categories, from smartphone to VSAT
- Dedicated spectrum, first < 6GHz, second Ku + Ka band & others
- Higher capacity, multiple use cases

NTN: TRANSPARENT VS REGENERATIVE PAYLOAD

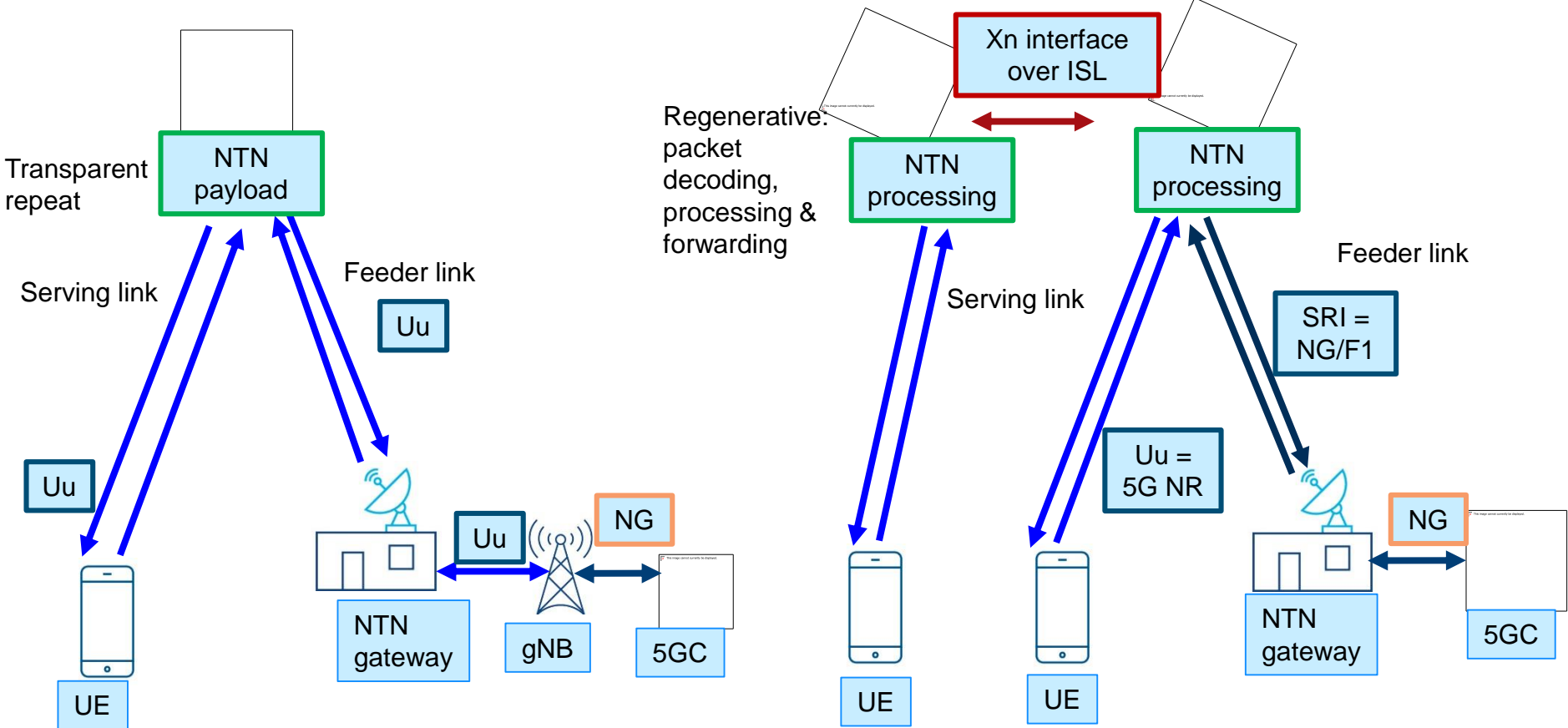

SPECTRUM TOPICS FOR NTN – COEXISTENCE

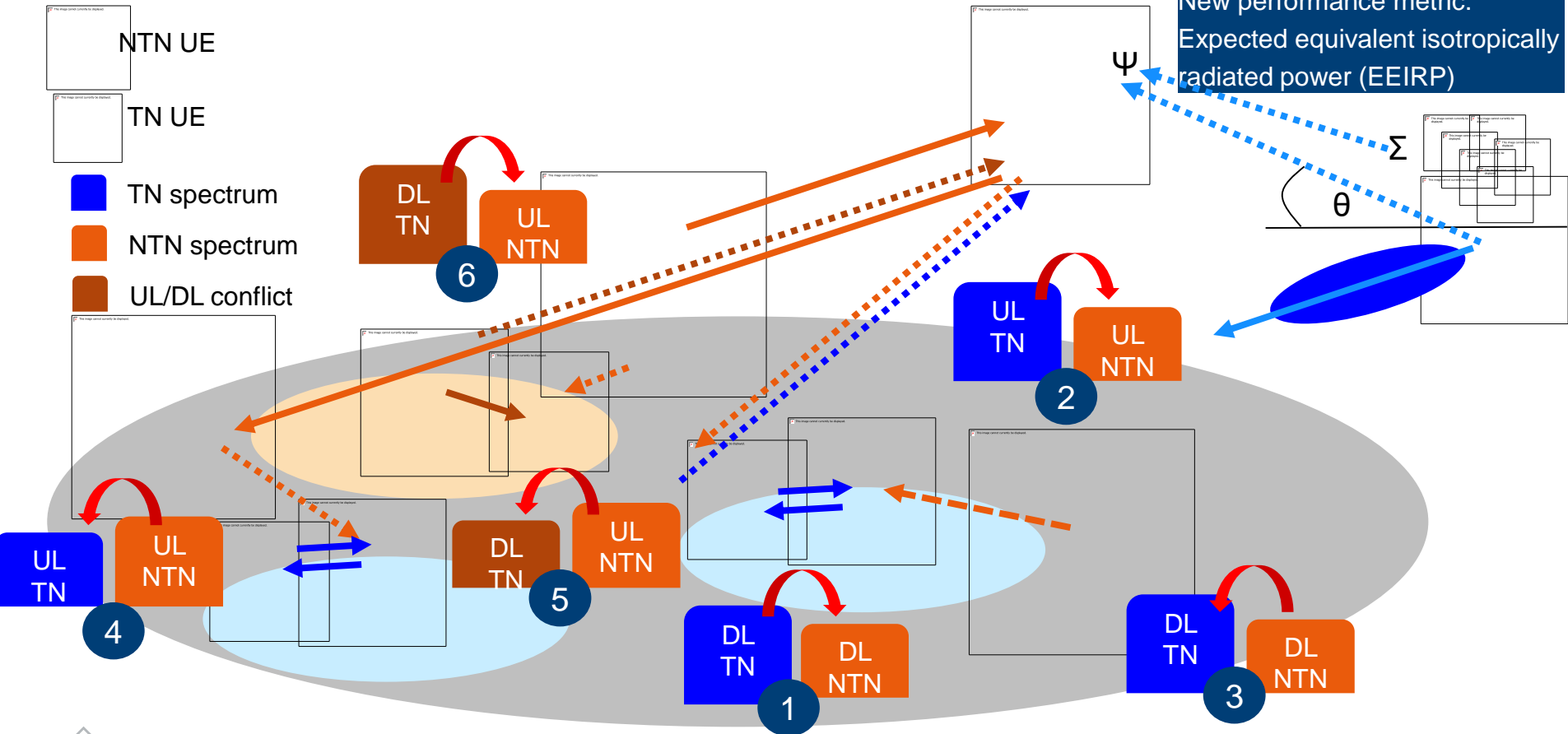

ITU: POWER FLUX DENSITY (PFD) DEFINITION

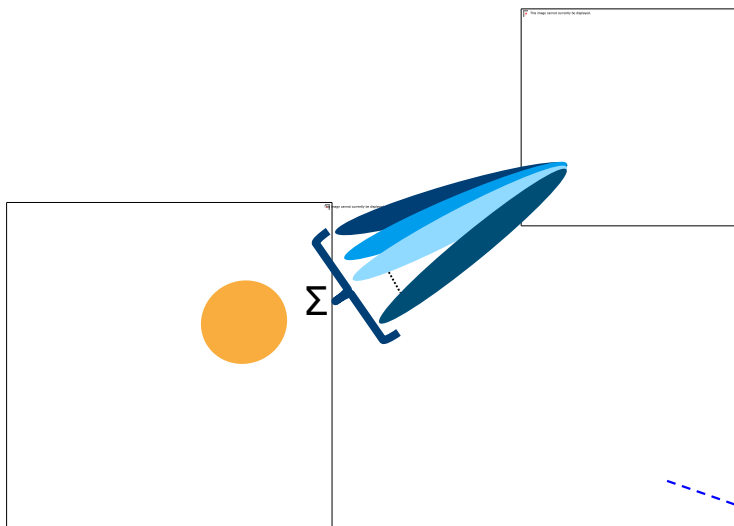

Power flux density = power emitted by satellite (given as sum of N beams) as measured at a reference area

$$PFD = \sum_{i=1}^N \frac{P_{Tx,i} \cdot G_{Tx,i} \cdot L_{Feeder}}{4\pi d^2}$$

$$PFD = EIRP_{dB} - 10 \log_{10} \frac{4\pi d^2}{\lambda^2}$$

Adjacent satellite interference (ASI)
=> off-axis power flux density

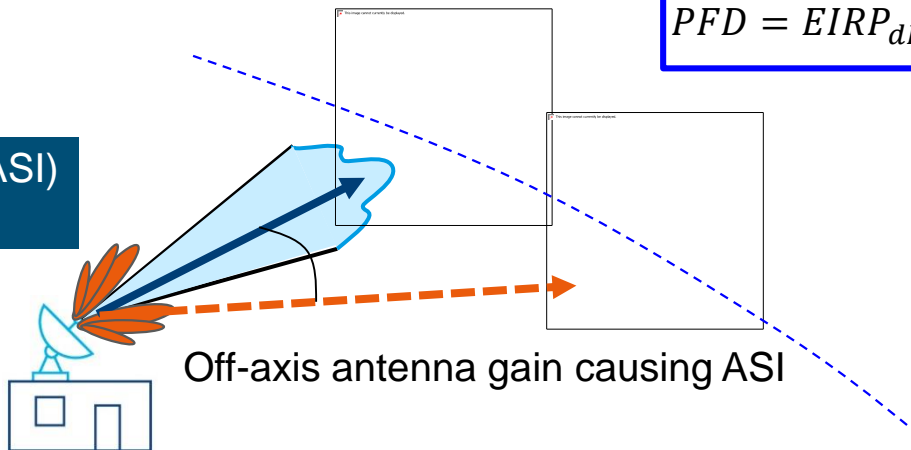

Off-axis antenna gain causing ASI

EXPECTED EQUIVALENT ISOTROPICALLY RADIATED POWER

Motivation: Upper 6GHz (6425 – 7125 MHz) conflicts with FSS (6425 MHz – 7025 MHz)

Unintentional and aggregated TX power cause coexistence issues, e.g. FSS satellite interfered by terrestrial TX

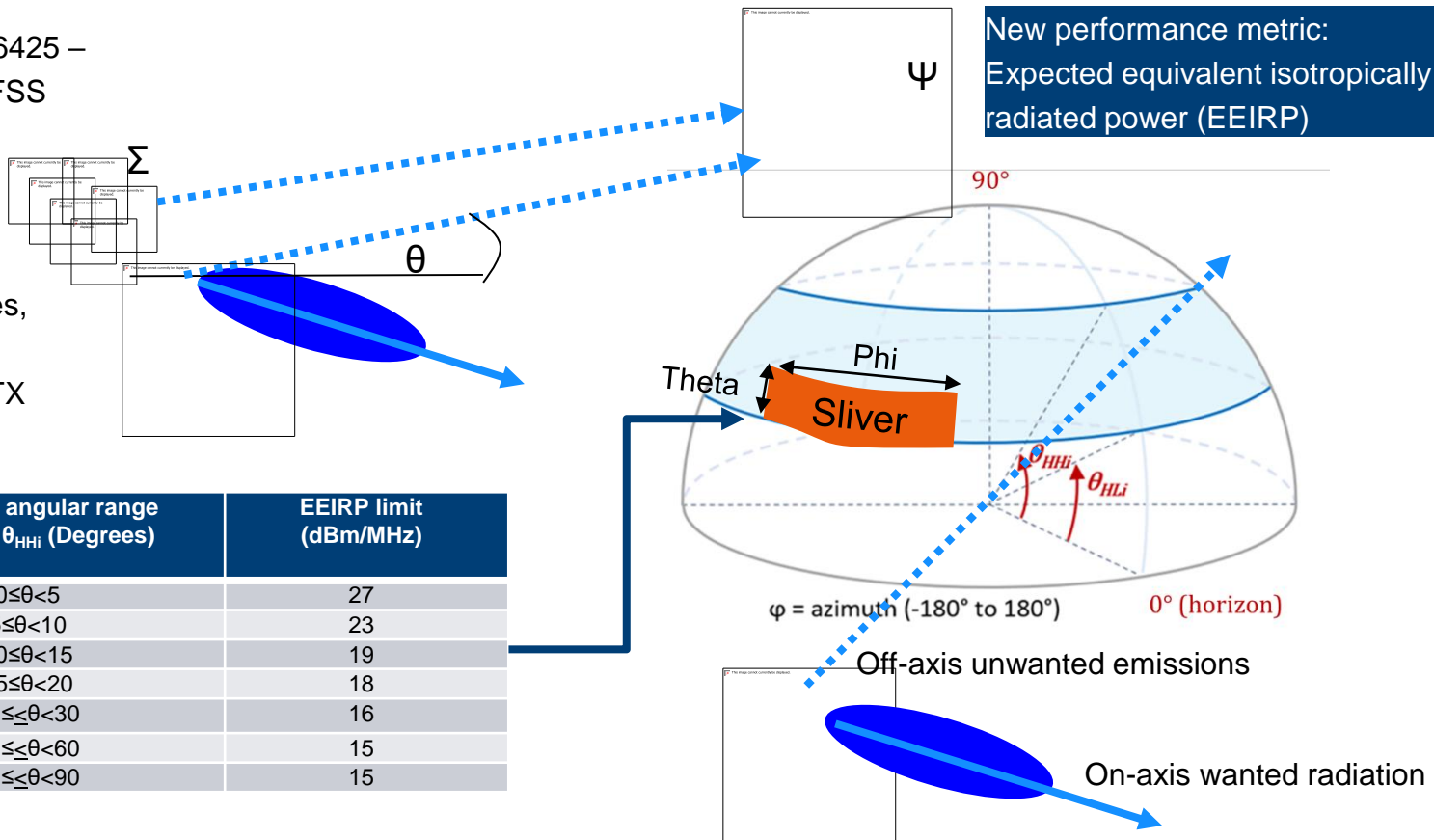

5G-NTN: PROTOCOL STACK

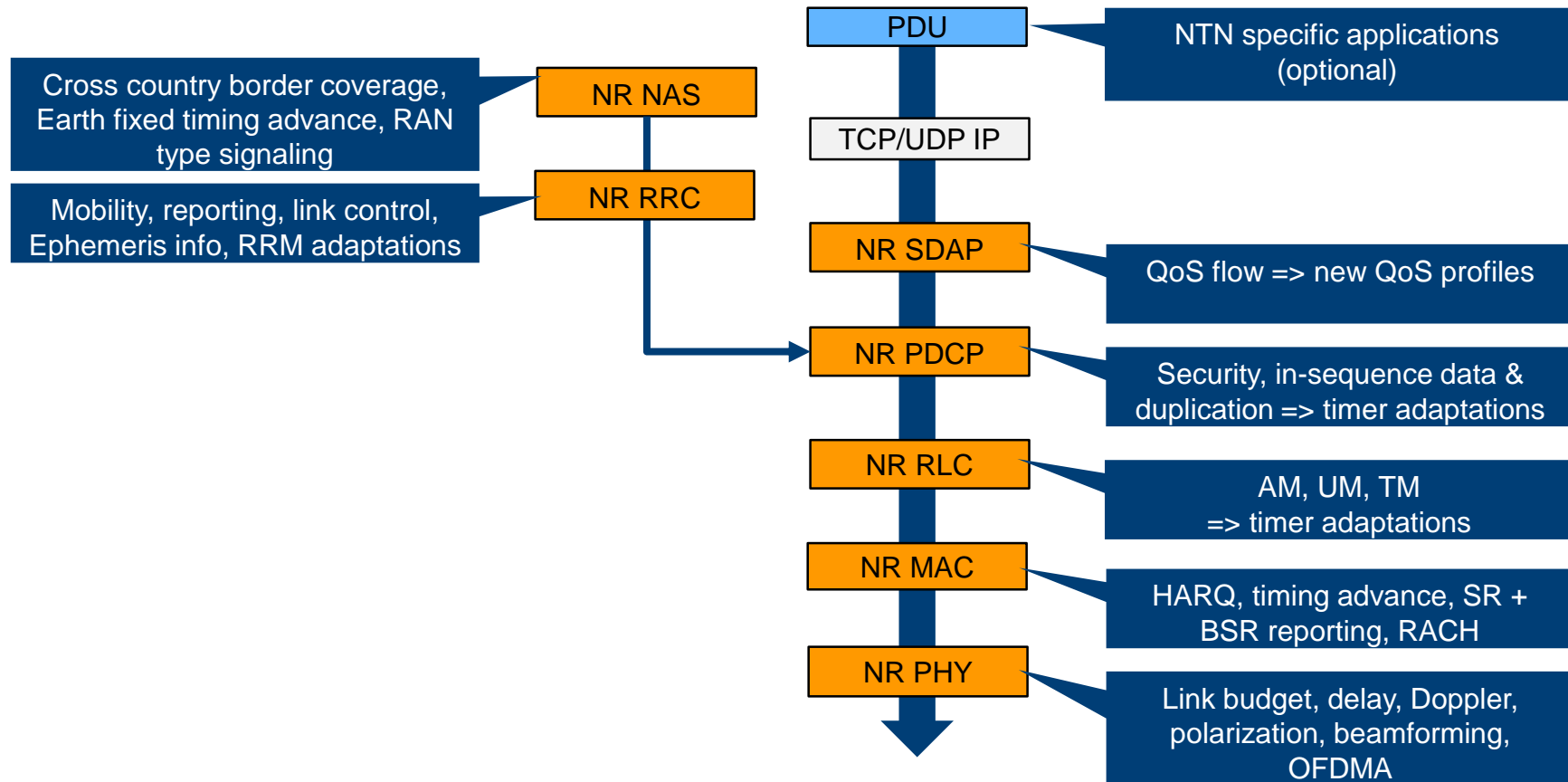

5G NTN MOBILITY SCENARIOS – BASELINE HANDOVER

5G NR baseline handover procedure: Inter-gNB procedure

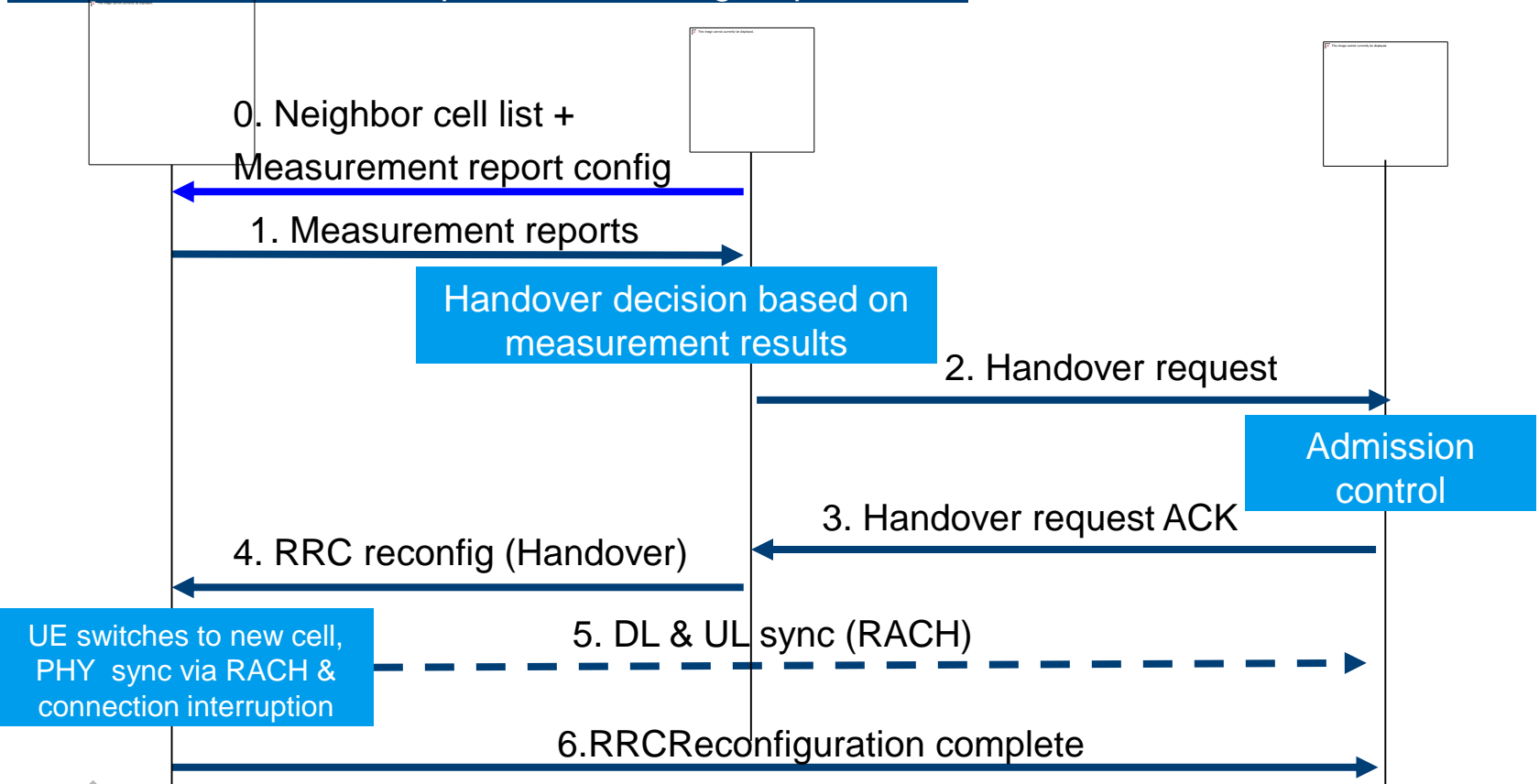

5G NTN HANDOVER EXAMPLE (CHO)

CONDITIONAL HANDOVER – SIGNALING PLANE

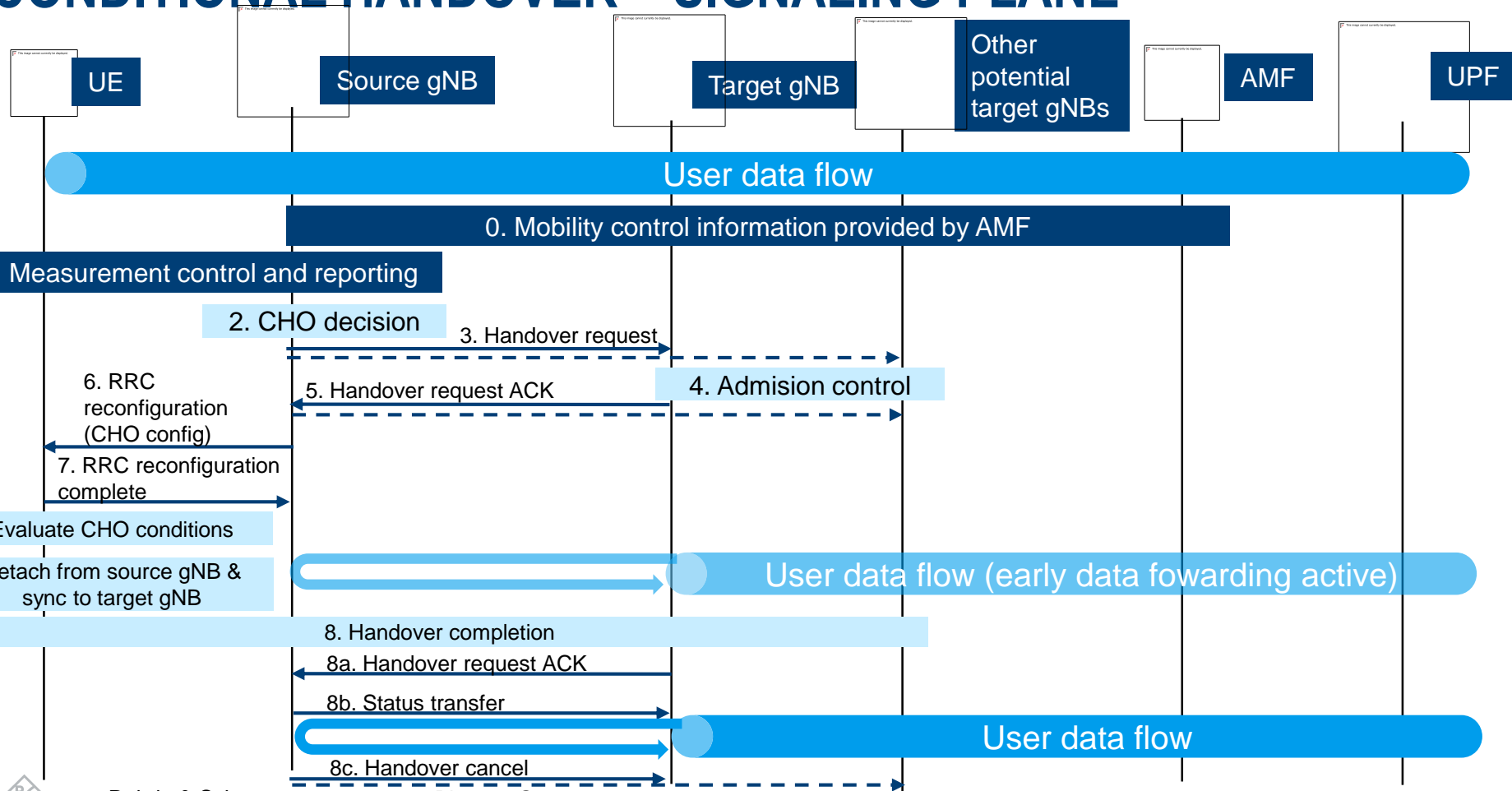

ROHDE & SCHWARZ SOLUTIONS SUPPORT FOR THE WHOLE SATELLITE ECOSYSTEM



Test solutions for satellite components and antennas



Components and systems for satellite ground stations



Satellite monitoring and link planner solutions



User Equipment Test and End2End simulations

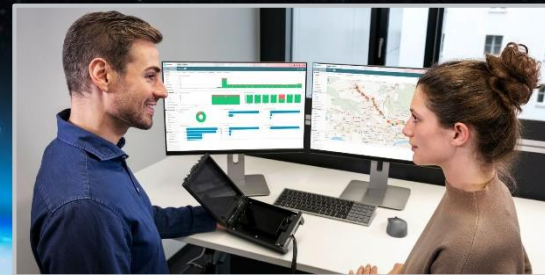

Field test QoS monitoring

30 MIN SATCOM ANTENNA TESTING BREAKTHROUGH

Rohde & Schwarz + Greenerwave just measured a 50cm Ku-band ESA full radiation pattern in 32 minutes using near-field setup, results match simulation within 1 dB accuracy.

The Problem Solved: No more massive far-field chambers or slow CATR positioning for large antennas.





MAIN TECHNOLOGY PILLARS

NTN

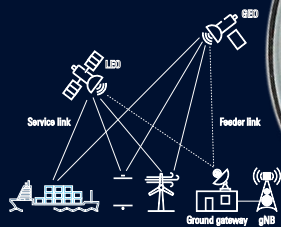

The Metaverse and eXtended Reality (XR)

AI -RAN



FR3 / Giga-MIMO



Integrated sensing and communication



Enhanced Duplex



Open networks and distributed computing



Photonics



Security & Trustworthiness

XR DEFINITION AND TECHNICAL TERMS TO REMEMBER

MOTION TO PHOTON (M2P) LATENCY

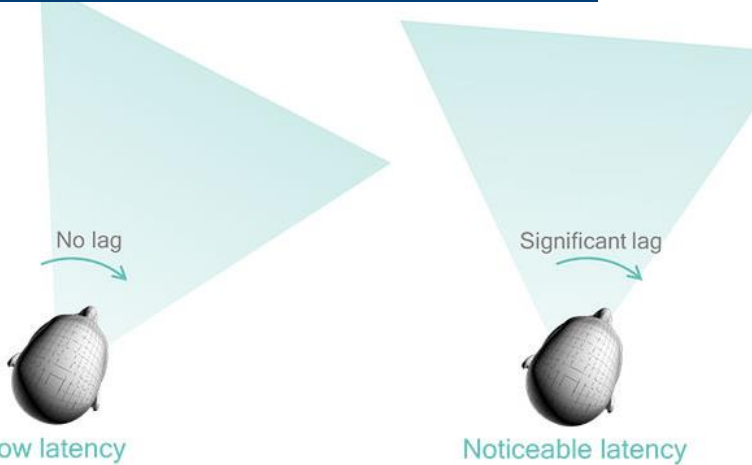

Source: <https://www.qualcomm.com/news/onq/2016/06/keeping-virtual-world-stable-vr>



DEGREES OF MEDIA

DEGREES OF FREEDOM (DOF)

3 degrees of freedom (3-DoF)



- Can only watch

6 degrees of freedom (6-DoF)

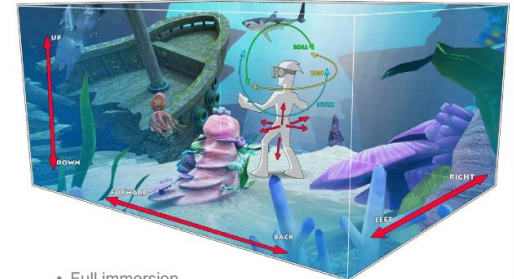

- Full immersion
- Can become part of the story
- Can now interact and change the story

Source: Qualcomm

Immersive Reality Video Types

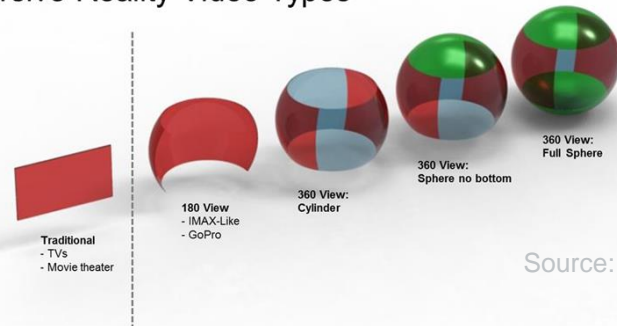

Source: Samsung

SAMSUNG TOMORROW

CARRIER-GRADE LAB-BASED TESTBED FOR EXTENDED REALITY (XR) FROM AN END-TO-END (E2E) PERSPECTIVE

“XR Testing App”



Full automation of the XR testbed via R&S@CMsequencer¹⁾, incl. XR Testing App

Ericsson, in collaboration with T-Mobile and Qualcomm, begins XR trials on 5G Standalone network

Available in English 日本語 简体中文

As 5G mobile adoption continues to grow rapidly, the convergence of 5G Standalone (5G SA) deployments, the feasibility of slim form-factor AI Augmented Reality (AR) glasses tethered to 5G-capable smartphones, and advanced 5G infrastructure capabilities create a perfect opportunity to trial the next wave of 5G low latency operator services, such as Extended Reality (XR).

PRESS RELEASE | MAR 04 2025

R&S@CMX500
5G One Box Signaling Tester

R&S@ATS1800C
Compact 3GPP-compliant OTA chamber for 5G NR mmWave signals



MAIN TECHNOLOGY PILLARS

NTN

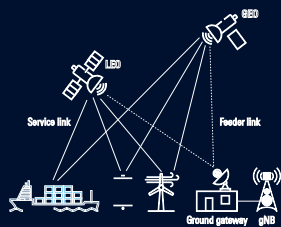

The Metaverse and eXtended Reality (XR)

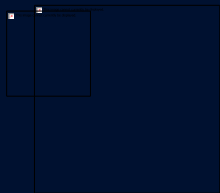

AI -RAN



FR3 / Giga-MIMO



Integrated sensing and communication



Enhanced Duplex



Open networks and distributed computing



Photonics



Security & Trustworthiness

6G FOR AI

CONCEPT FOR TESTING QOS OF AI-AS-A-SERVICE

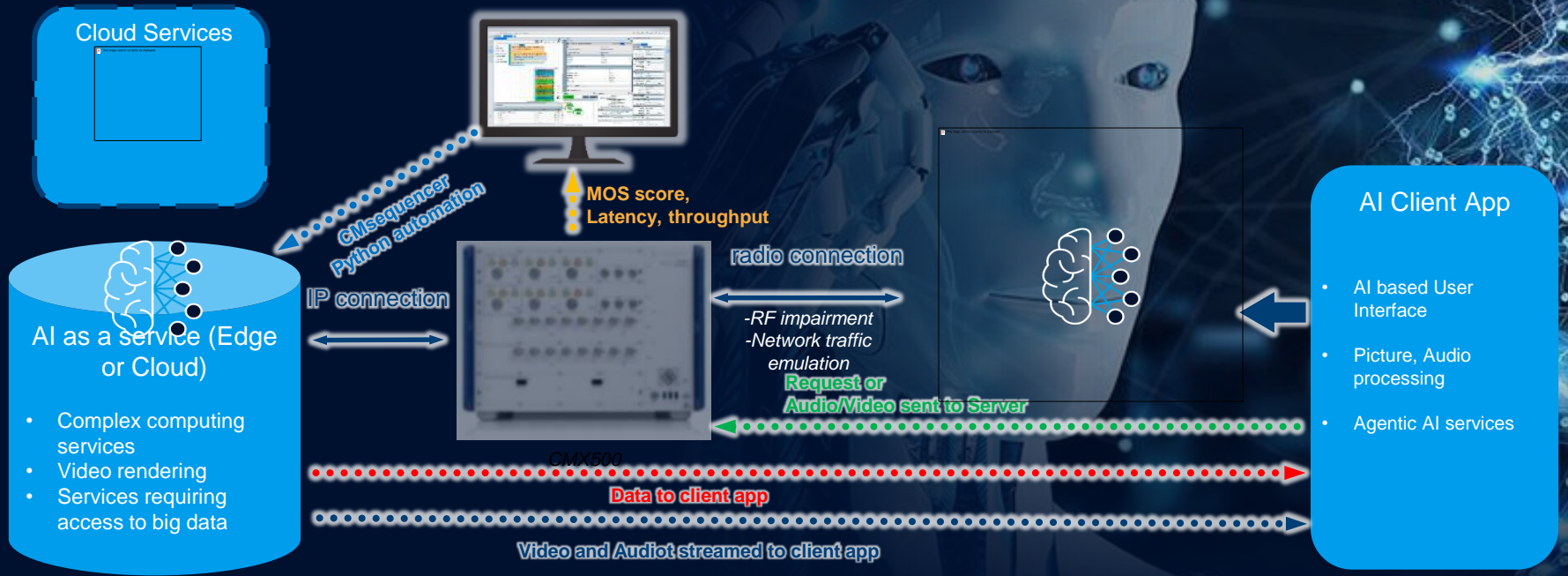

THANK YOU TO THE AI-RAN ALLIANCE

GIVING STRUCTURE TO AI APPLICATIONS



AI on RAN

- Aims to enable new RAN services to enhance AI applications running at the network edge, to be able to offer new consumer and enterprise services and applications from the edge of the network

AI for RAN

- Focusing on the integration of AI into RAN to significantly enhance RAN performance, such as improving spectral and operational efficiency, optimizing radio resource management, and enabling predictive maintenance

AI and RAN

- Seeks to create a shared infrastructure between RAN and AI workloads, enabling concurrent resource utilization on this converged computer-and-communications infrastructure

AI FOR RAN IN 3GPP

LAYING THE FOUNDATION WITH 5G-ADVANCED

► 3GPP Release 18: 5G-Advanced

- SA1-led study on model transfer ([TR 22.874](#)), SA2-led study on 5G system support for AI/ML-based services ([TR 23.700-80](#)), SA4-led study on AI/ML for media ([TR 26.927](#)) and an SA5-led study on AI/ML management ([TR 28.908](#)), RAN3-led continuation based on findings in Rel-17 study item
- AI/ML for NR air interface – [3GPP TR 38.843 V18.0.0 \(2023-12\)](#)
 - Exploration of augmentation of the **5G air interface** by AI/ML, starting with **four pilot use cases** in 3GPP Release 18/19 to assess performance in **comparison to conventional methods** and **specification impact**

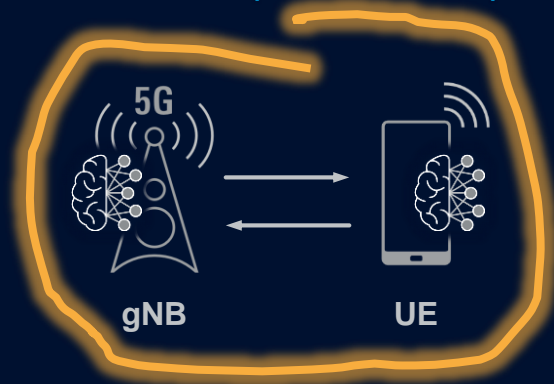
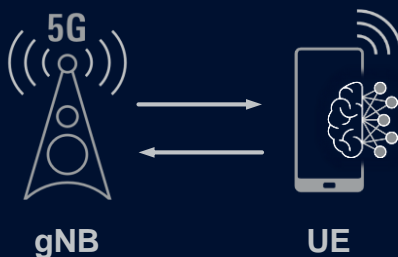
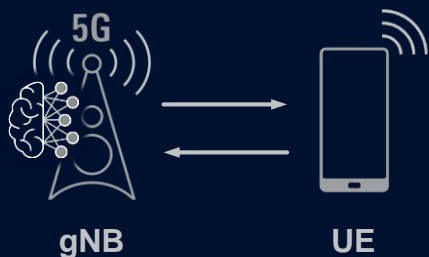

MOBILE WORLD CONGRESS 2025

DEMO IMPRESSIONS

Demoed @

MWC
GSMA

BARCELONA
3 - 6 MARCH 2025

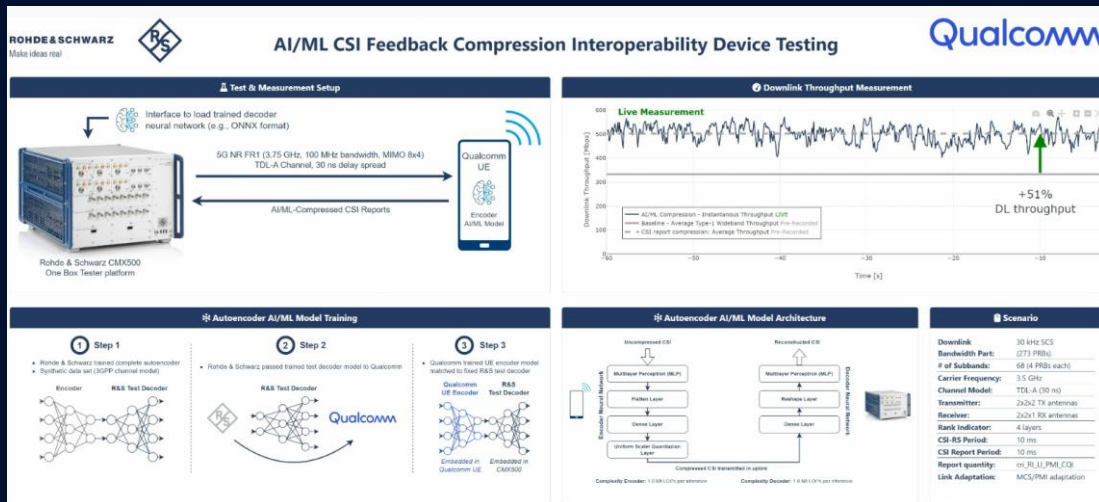

- ▶ Interoperability testing of CSI Feedback Compression based on R&S CMX500
- ▶ Import and inference of ONNX-formatted decoder AI/ML models
- ▶ Addressed the concerns of 3GPP wrt testability and allowed CSI FB Comp to become a WI in Rel-20



TOWARD AN AI-NATIVE AIR INTERFACE FOR 6G

NEURAL RECEIVER WITH CUSTOM CONSTELLATION

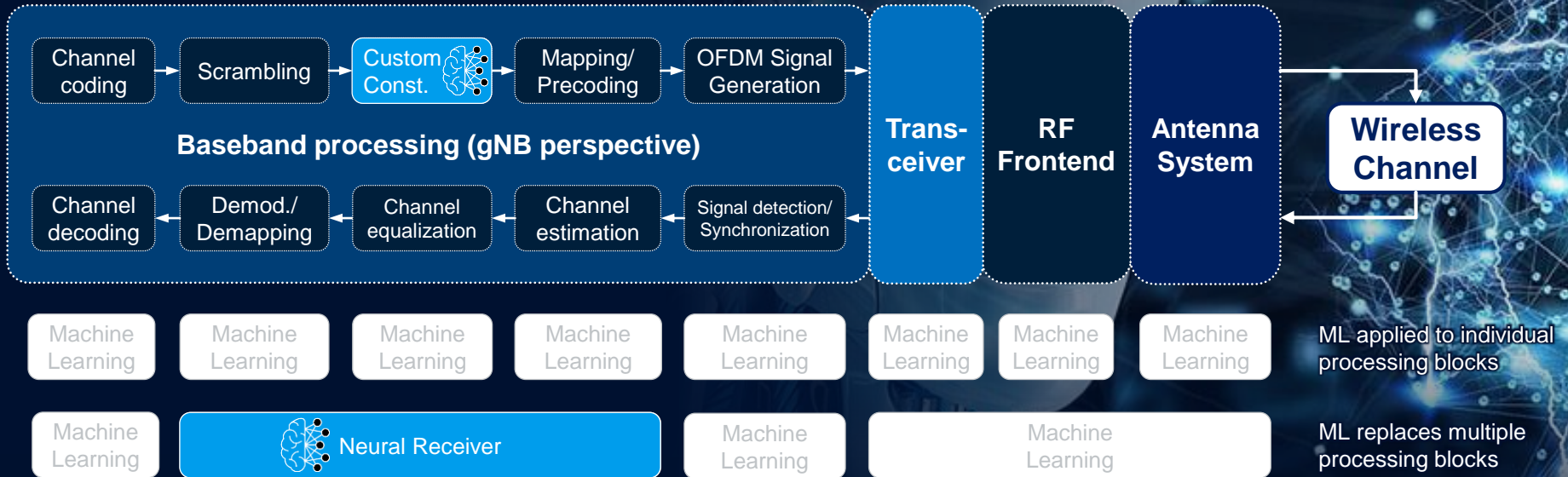

Modulation scheme constellation aspects

Reminder 16QAM

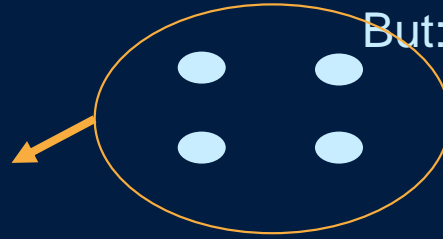
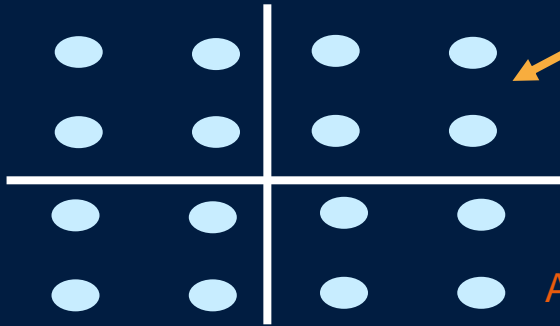

But: every quadrant is identical

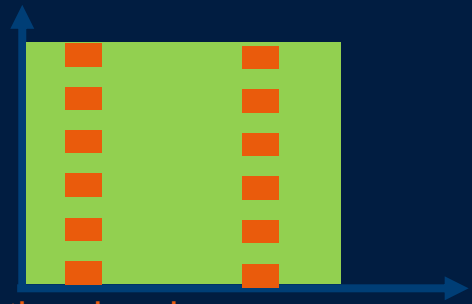

As radio channel (Fading) deteriorates the signal, we need pilots, e.g. DMRS for channel estimation and equalization

Idea: If we apply a scenario specific, pseudo-random looking constellation diagram, we may understand the constellation position as kind of reference signals

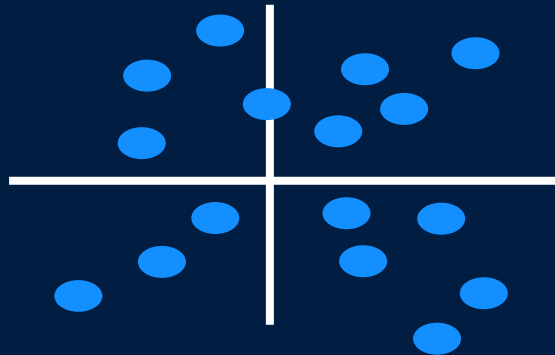

TOWARD AN AI-NATIVE AIR INTERFACE FOR 6G NEURAL RECEIVER WITH CUSTOM CONSTELLATION

Toward 6G: AI/ML-based Neural Receiver, Custom Constellation and Impairment

Custom constellation
= super-imposed pilot sequence

Reset Figure Requesting 10 samples. Progress: 99/100, BLER 0.00200.

Measure Performance SNR [dB]: -1.0

- Evaluate LS-Baseline
- Finetuned Neural Receiver
- Show Goodput
- Carrier Frequency Offset [ppm]: 0.2

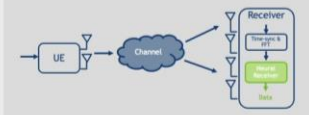

Channel TDL-B 100ns/400Hz

Number of PRBs	273 (100 MHz)
Modulation order	16
Target code rate	0.54
Transport block size	92200 bit
DMRS Overhead	3276 REs
Effective PUSCH throughput	58.8 slots/s
Occupied REs Baseline	45864
Occupied REs NRX	42588

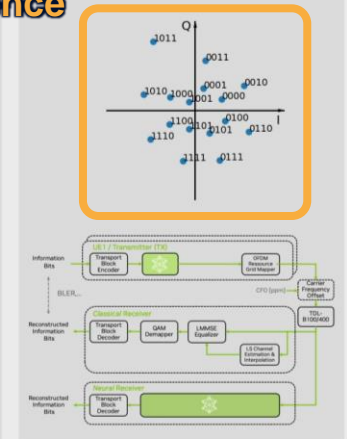
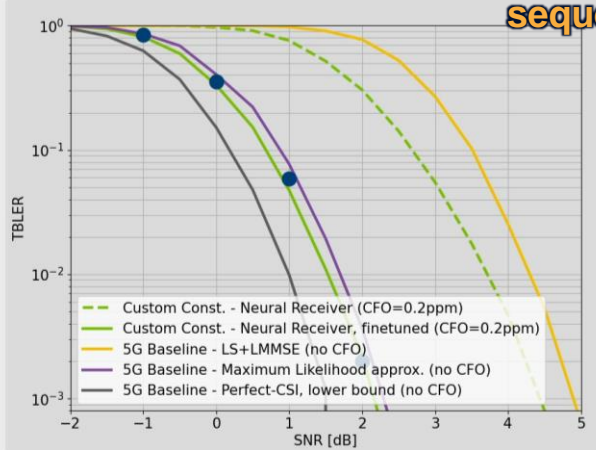

Depending on actual DMRS configuration (pilot signal) up to 14% gain in spectral efficiency

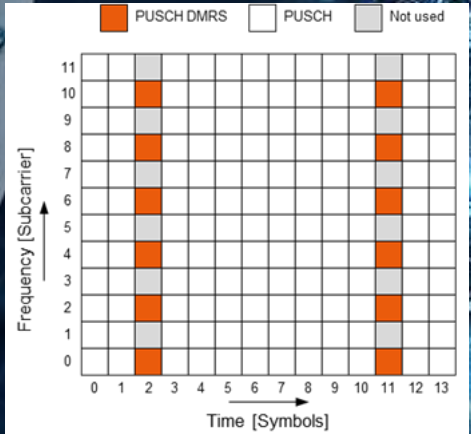

12 x 14 = 168 RE
12 RE for pilots, 12 RE unused
24/168 = ~14%

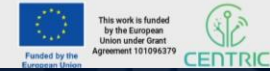

END-TO-END Constellation Learning

- ▶ Joint **End-to-End Learning** (TX, wireless channel, RX) of custom constellation points and neural receiver
- ▶ AI/ML models learn constellation with superimposed pilots; joint optimization of neural receiver performance
- ▶ **Pilotless Communication:** No need for 5G NR Demodulation Reference Signals (DMRS)
- ▶ Free resources can be used for data transmission
→ higher bandwidth efficiency/throughput
- ▶ **Additionally in this demo:** Neural RX trained with carrier frequency offsets in range 0 – 0.5 ppm

From QAM16...

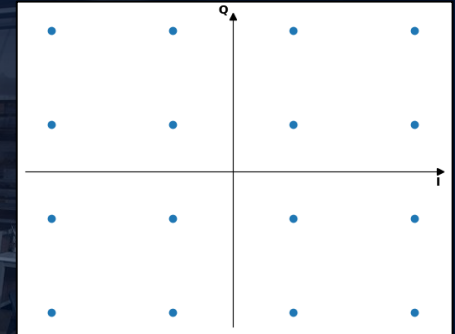

... to an AI/ML-learned constellation

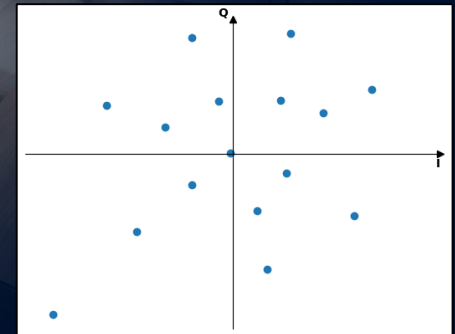

THE NEXT STEP – TRENDS IN RESEARCH

DIGITAL TWINS FOR AI-RAN

Demoed @ **MWC**
GSMA

BARCELONA
3 - 6 MARCH 2025

Towards 6G: Digital Twins for the AI-RAN

Stop Demo Reached last position
Restarting measurement.

Number of PRBs	273
Number of RX antennas	4
Modulation order	16-QAM
Target code rate	0.534
Transport block size	83976 bit
NRX PUSCH throughput (slots)	211.1 slot/s
NRX PUSCH throughput (bits)	35.5 Mbit/s
Mobility UE-0	7 m/s
Mobility UE-1	6.2 m/s

Show coverage map

Show goodput

Evaluate site-specific NRX

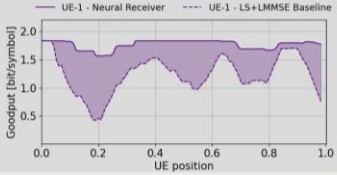
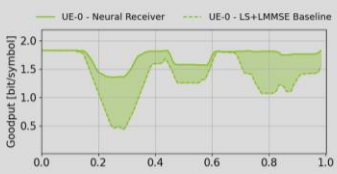
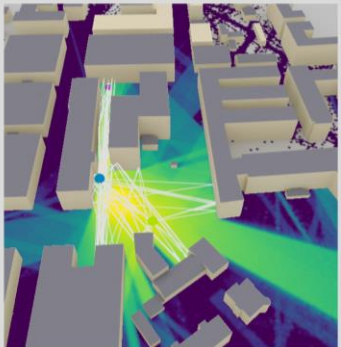

ROHDE & SCHWARZ

Made with NVIDIA SIEMENS

6G-ANNA

This work is funded by the European Union under Grant Agreement 101016179

Rohde & Schwarz advances AI/ML-powered neural receiver testing in collaboration with NVIDIA

Rohde & Schwarz, in collaboration with NVIDIA, has achieved a significant breakthrough in AI-driven wireless communication research. The latest proof-of-concept to be showcased at MWC 2025 in Barcelona leverages digital twin technology and high-fidelity ray tracing for more realistic testing of neural receivers for 5G-Advanced and 6G.



AI/ML-based neural receiver with NVIDIA as seen at MWC Barcelona. (Image: Rohde & Schwarz)

Rohde & Schwarz continues to push the boundaries of AI-driven wireless communication research with its latest milestone in neural receiver design and testing. To be showcased at MWC 2025 in Barcelona, the latest proof-of-concept, developed in collaboration with NVIDIA, integrates digital twin technology and high-fidelity ray tracing to create a robust framework for testing 5G-Advanced and 6G neural receivers under realistic propagation conditions. The objective is to bridge the gap between AI-driven wireless simulations and real-world deployment, thereby facilitating more efficient and accurate testing of next-generation receiver architectures.

site-specific adaptation of a **neural receiver** model by ray tracing simulation to accurately characterize the wireless channel in the targeted deployment area

BRING RAY-TRACING TO THE LAB

R&S®SMW200A
Vector Signal Generator with
Customized Dynamic Fading



Transition ray tracing
simulation into fading
profile using customized
dynamic fading option



Ansys

RF Channel Modeler
generates custom
wireless channel models
for laboratory testing of
real 5G/6G hardware

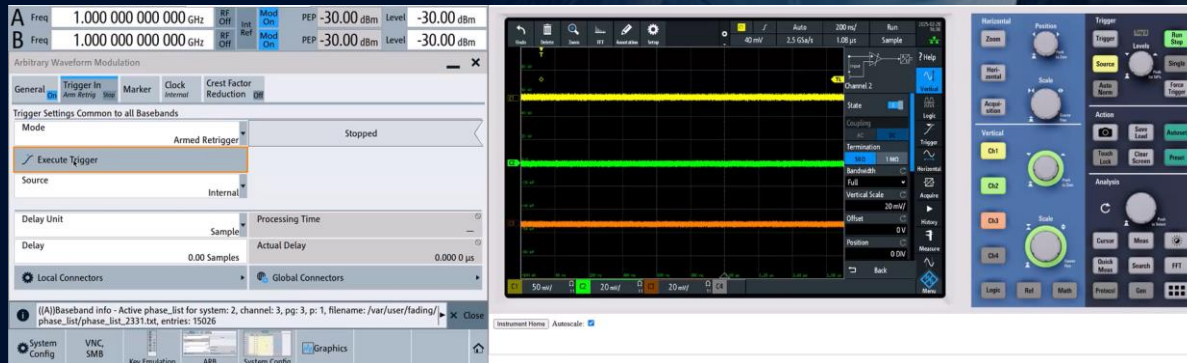

IMPROVING UL PERFORMANCE WITH AI

COMBINE NEURAL RECEIVER AND DIGITAL POST-DISTORTION (DPoD)

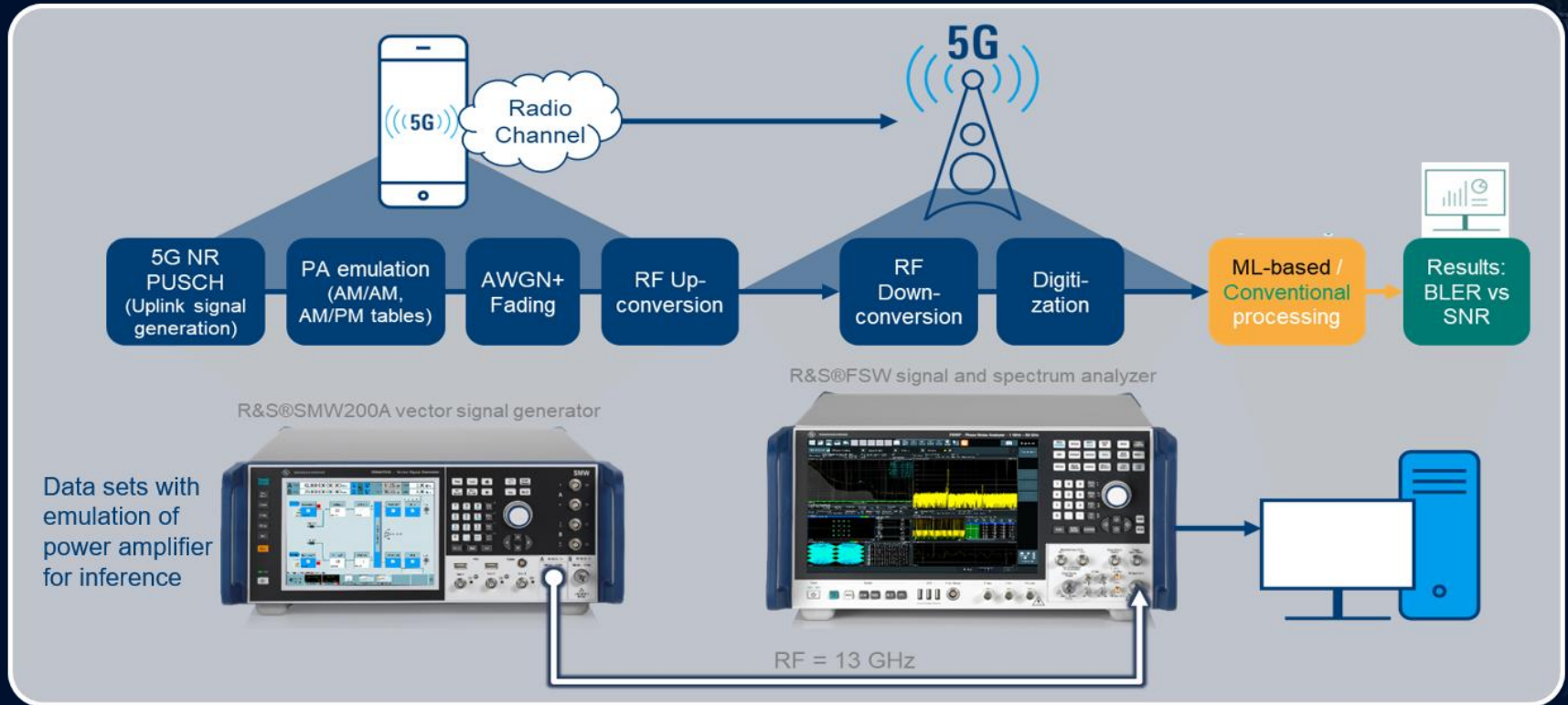

EXAMPLE SHOW CASE

DPOD

The [Brooklyn 6G Summit](#) is a premier event for the global communications industry, bringing together leading voices from technology, business, academia and regulation to shape the future of wireless.

Jointly organized by Nokia and the NYU WIRELESS research center at the NYU Tandon School of Engineering, the Summit has been instrumental in shaping the trajectory of wireless communications since its inception in 2014.

The 12th edition was held on November 5–7, 2025, at the NYU Tandon School of Engineering.



TESTING THE AI-NATIVE AIR INTERFACE

OVERVIEW OF TEST SOLUTIONS

Open Neural Network Exchange

R&S testbed for hardware-in-the-loop validation of AI/ML neural receiver performance (e.g., AI/ML channel estimation, equalization, compensation of non-linear impairments) with RF digital twins for site-specific wireless channel emulation

RF Digital Twin for AI-RAN Testing

Site-specific channel emulation leveraging raytracing

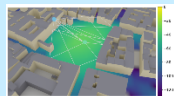

NVIDIA
SionnaRT



AI/ML-Learned Custom Constellations

Evaluation of learned constellations as a stepping stone to pilotless communication

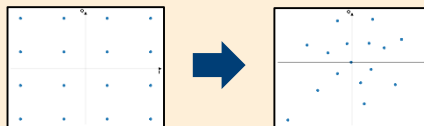

Neural Receiver Performance Analysis

Integration of Neural RX into R&S instruments for hardware-in-the-loop performance analysis

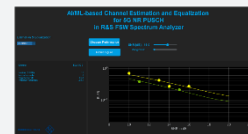

Bring-your-own-model

Load time-variant wireless channel



R&S SMW200A Vector Signal Generator

Load trained custom constellations

5G NR Signal



R&S FSWX Spectrum Analyzer & Vector Signal Explorer SW

Import trained neural network (ONNX model)

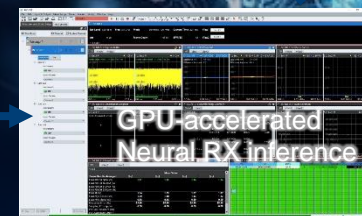



MAIN TECHNOLOGY PILLARS

NTN

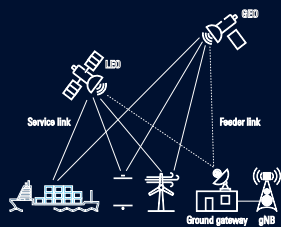

The Metaverse and eXtended Reality (XR)

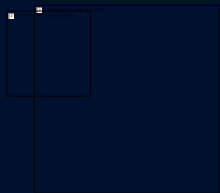

AI -RAN



FR3 / Giga-MIMO



Integrated sensing and communication



Enhanced Duplex



Open networks and distributed computing



Photonics



Security and Trustworthiness

R&S®CMX500 5G ONE BOX SIGNALING TESTER

SUPPORTS EXISTING (FR1) AND FUTURE (FR3) FREQUENCY BANDS

- ▶ Using the Intermediate Frequency unit (IFU; 4...20 GHz) of our platform to support early testing at FR3 frequencies using the R&S®CMX500 One-Box Signaling Tester
 - Uses the official 5G NR protocol stack, 100 MHz, SCS 30 kHz with DL MIMO 4x4

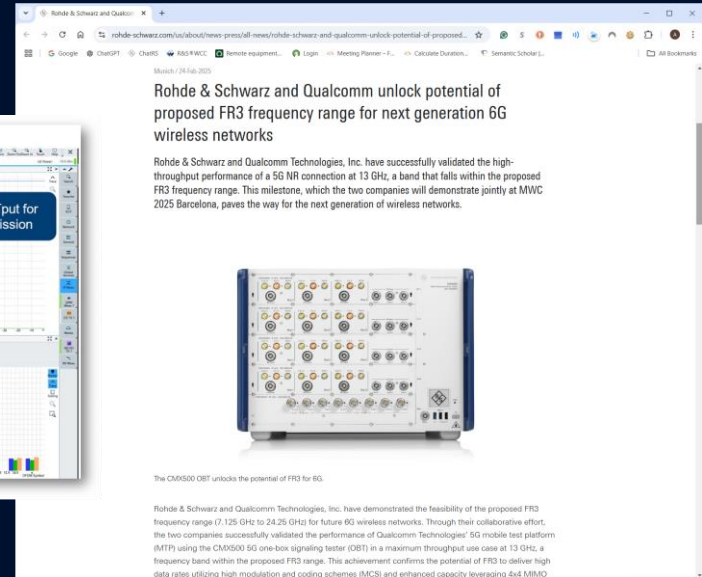
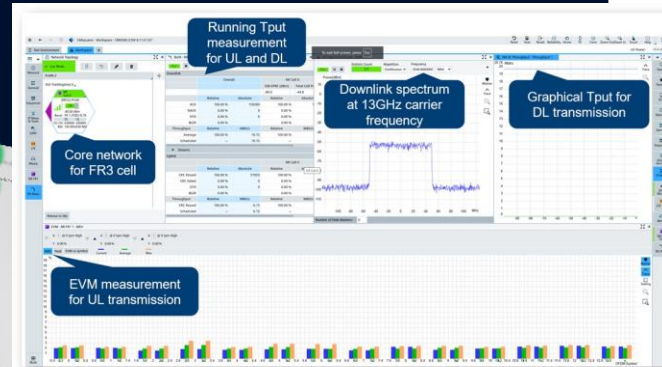

6G – MIMO: ELECTRONIC STEERABLE ARRAYS (ESA)

IFF: R&S®ATS1800M

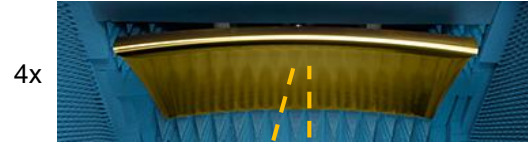
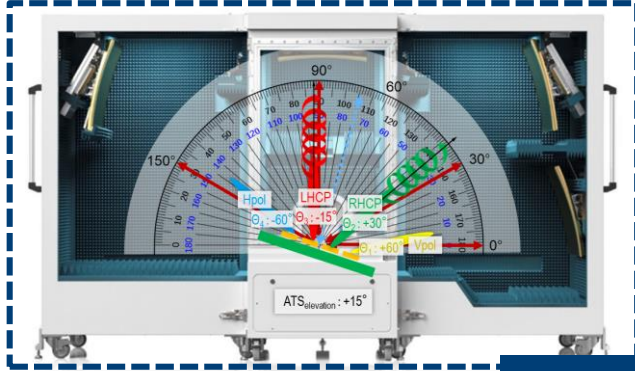

4x

4x Dual-polarized feed antenna

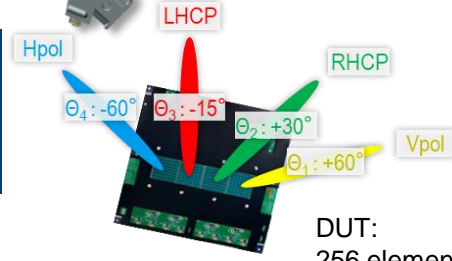

1x4 PAAM

DUT: 256 elements

Oscilloscope: R&S®RTO



FSW IF OUT
ZNA Ports 1 + 3
IF OUT

VNA: R&S®ZNA



mmW Couplers or Feed Antennas
IF Coupler
LO

Test concept for phased array antennas (PAAM) and ESA antennas



SG: R&S®SMA100
LO



VSG: R&S®SMW200A
IF H- and V-pol modulated signal with 90 degrees phase shift in PAAM



VSA: R&S®FSW43
mmW H-pol demodulation analysis, distortion without demodulation and linearization,



MAIN TECHNOLOGY PILLARS

NTN

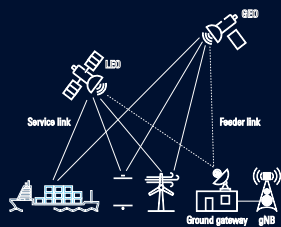

The Metaverse and eXtended Reality (XR)

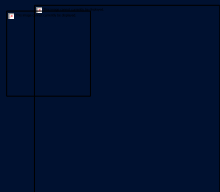

AI -RAN



FR3 / Giga-MIMO



Integrated sensing and communication



Enhanced Duplex



Open networks and distributed computing



Photonics



Security & Trustworthiness

Time-domain channel measurements for FCAS research

Characterization of Helicopter Rotor Blade Modulation in UHF and Microwave Bands

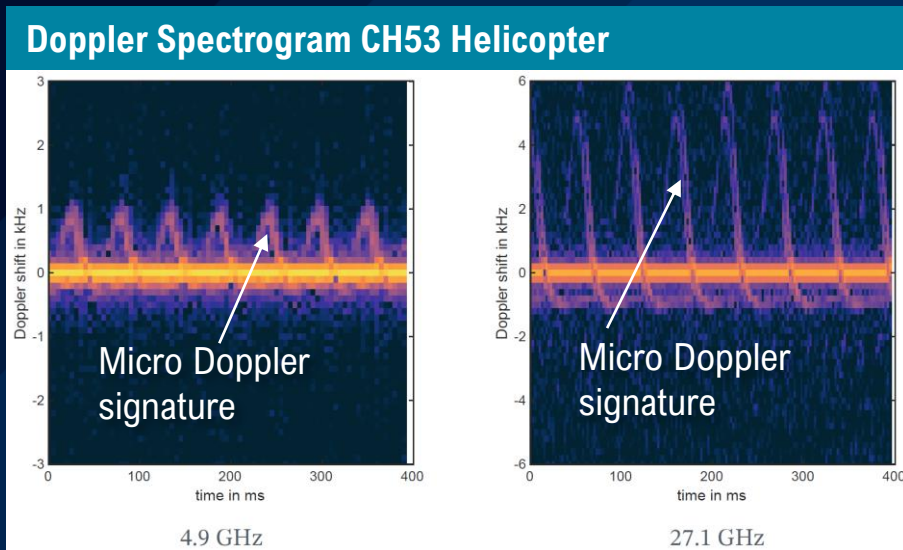

“Characterization of Helicopter Rotor Blade Modulation in UHF and Microwave Bands”, submitted to MILCOM2024

ISAC - USE CASES

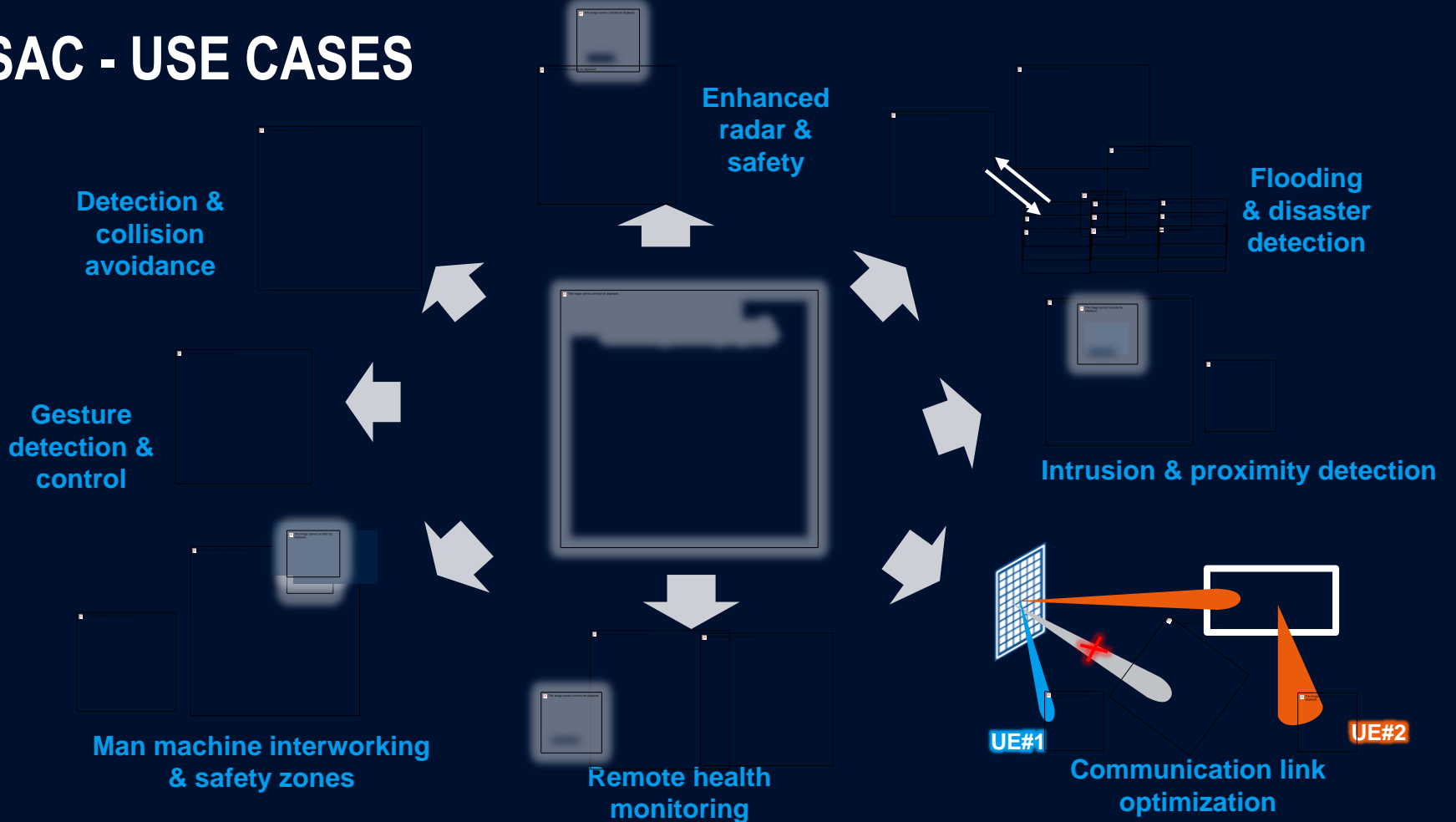

HUMAN SENSING IN FR3: NTT / DOCOMO 6G COLLABORATION

STATISTICAL EVALUATION OF TIME VARIATION OF PROPAGATION CHANNEL AT 7.9 GHZ FOR SENSING

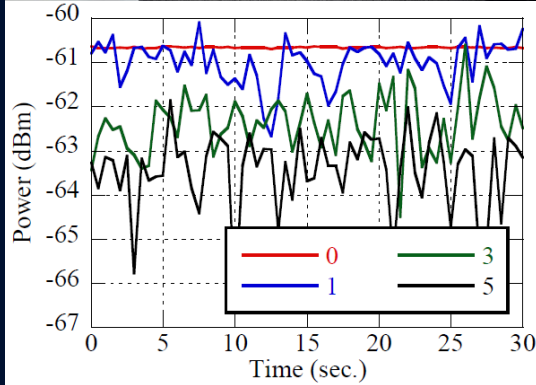

- ▶ Received power decreases as number of people walking around the table increases.
- ▶ Fluctuation of power increases as number of people walking increases.
- ▶ Next step:
 - ▶ Use AI for faster eval.
 - ▶ Use phase and wideband info

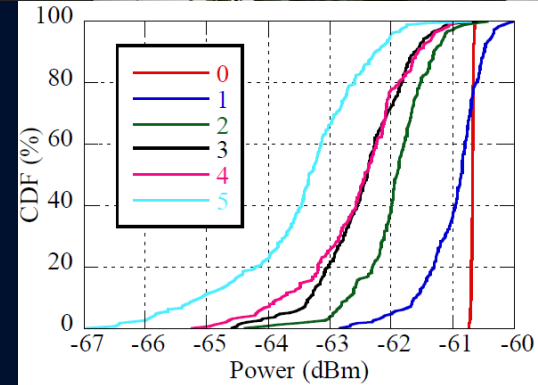

PRINCIPLES OF ISAC SENSING TESTING

KPIs



- Throughput
- Voice, video quality
- RF performance / linearity → EVM
- Power / Spectrum

Communication Channel

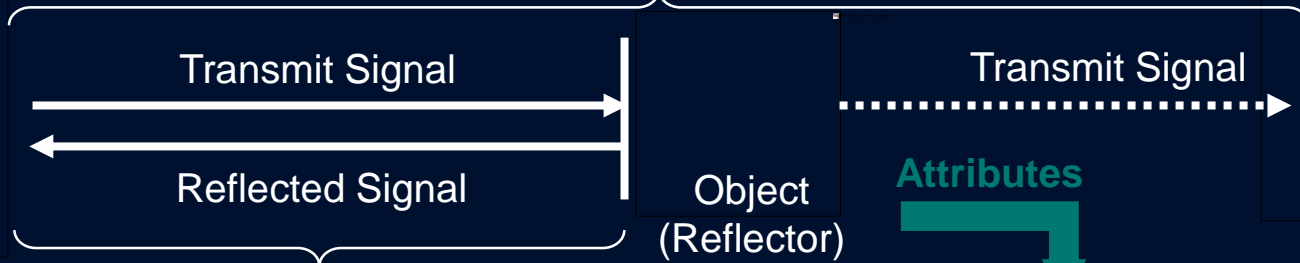

Sensor Channel

Attributes

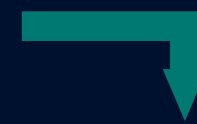

- Detection Accuracy
- Resolution

KPIs

- Speed
- Distance
- Angle
- RCS

Towards 6G

Integrated sensing and communication

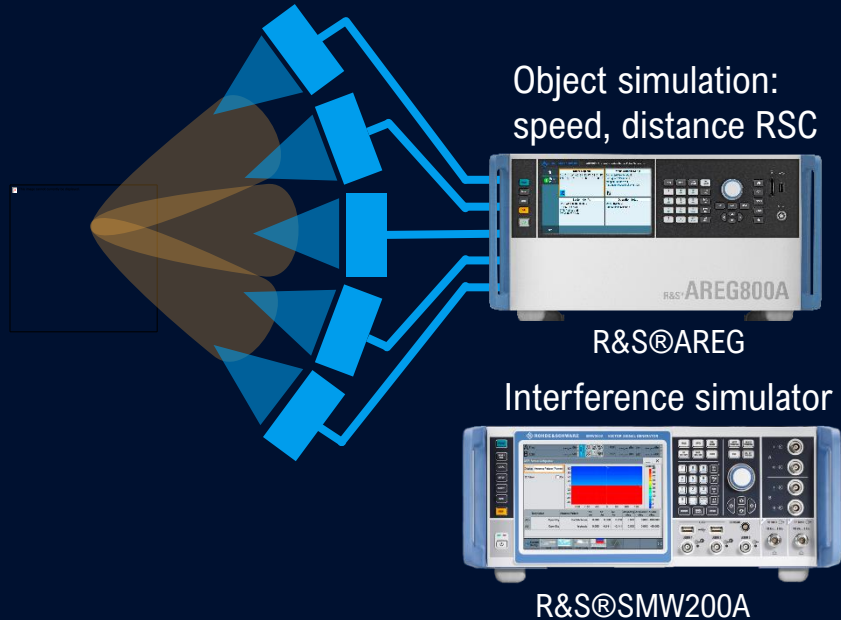

Verifying JCAS technology

- ◆ R&S@AREG800A Automotive Radar Echo Generator for object simulation and the R&S@FE44S external frontends.
- ◆ R&S@SMW200 to generate interference signals

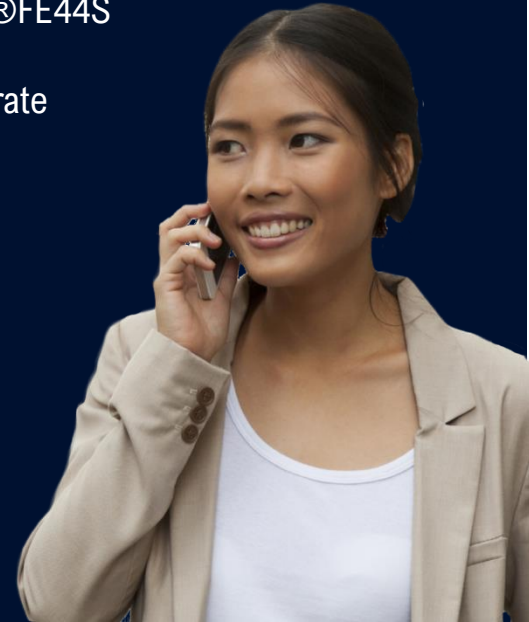

ISAC TEST SOLUTION IN PRACTICE

VERIFICATION OF TRACKING ALGORITHMS

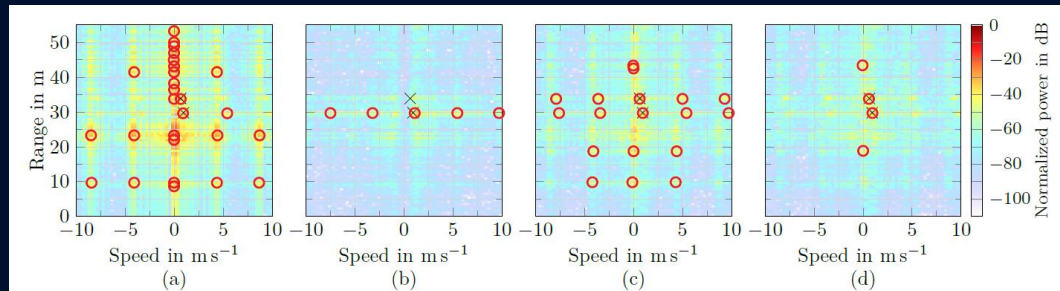

Fig. 5: Examples of measured periodograms after different steps of the processing pipeline. The ground truth objects are marked with (×) and the CFAR-detections with (○). (a) Original periodogram directly from the PoC, (b) after clutter removal with ECA-C, (c) after clutter removal with CRAP, (d) final version after TDD peak detection.

Demonstrating Multi-Object Tracking in Integrated Sensing and Communications with Real Hardware

Maximilian Bauhofer*, Marcus Henninger†, Meik Kottkamp‡, Lucas Giroto‡, Philip Grill‡
 Alexander Felix†, Thorsten Wild†, Stephan ten Brink*, and Silvio Mandelli‡
 *University of Stuttgart, Stuttgart †Nokia Bell Labs, Stuttgart ‡Rohde & Schwarz, Munich, Germany
 E-mail: bauhofer@inue.uni-stuttgart.de

Source: [Joint Nokia/R&S paper](#)

MULTI-LAYER MULTI-DIMENSION MULTI-BAND (ML-MD-MB) TOPOLOGY

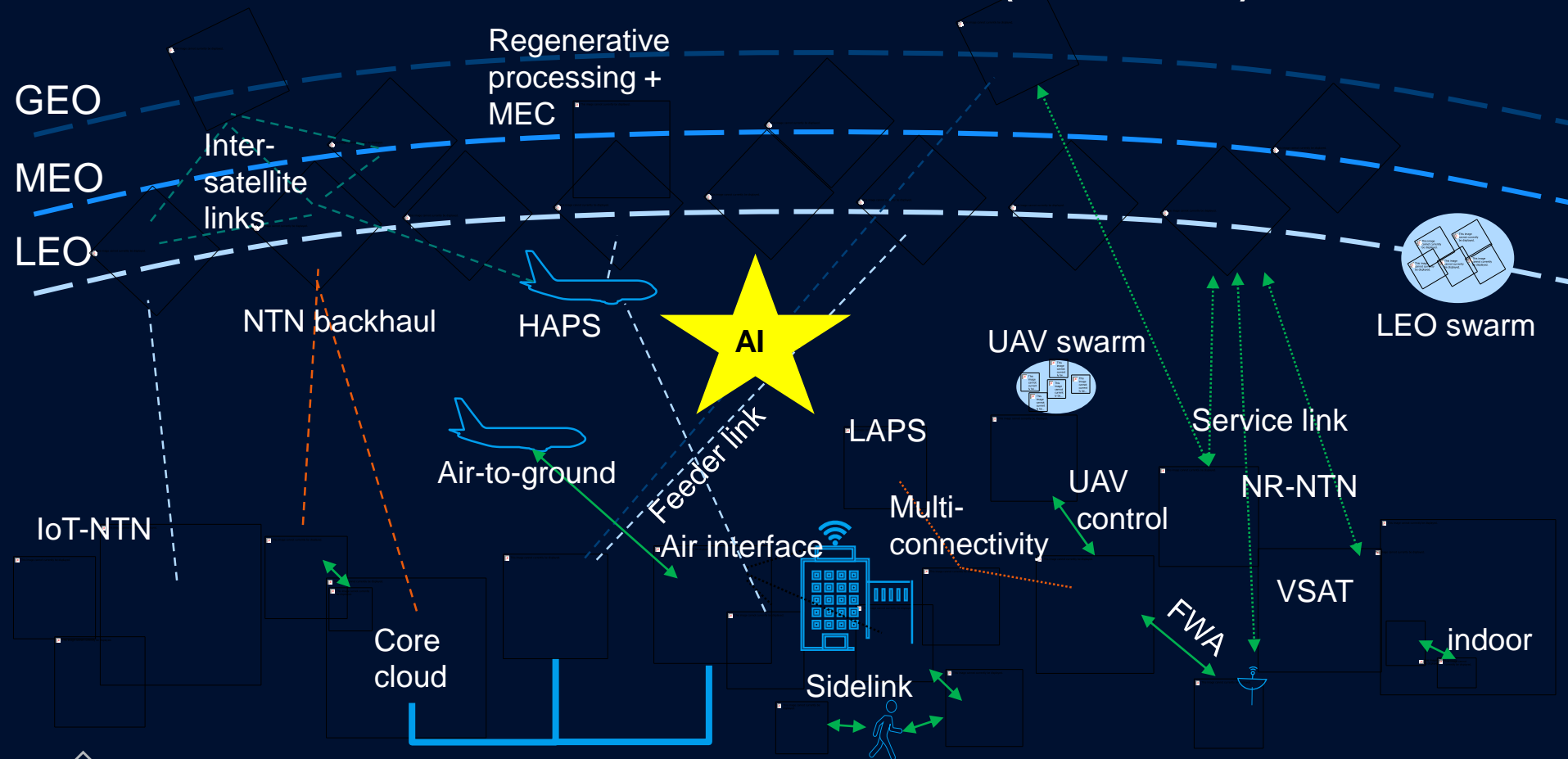

SUMMARY

- ▶ Deployment of 5G networks is still ongoing to reach its full capabilities and deliver on its promises
- ▶ Researchers in academia and industry have explored new technology components which will find their way into 3GPP specifications to make 6G networks and devices **more efficient, intelligent, sustainable, and secure**
- ▶ These new main technology pillars will enable the next step towards an **immersive, pervasive, digital experience** in a hyper-connected world
- ▶ **Rohde & Schwarz is actively engaged** in this phase of standardization and pre-development, providing our expertise in test and measurement to **make these ideas real**

THANK YOU!

“No one can whistle a symphony. It takes a whole orchestra to play it.”

Halford E. Luccock (1885-1960)

